

When the Boat Comes In

(All About Modelling Bulk Cargo Jetties)

Jodie Thompson

Dr John Henstridge

Data Analysis Australia

ASC - July 2002

A Quick Lesson on Bulk Cargo Facilities

- Importing (discharging) and Exporting (loading) capabilities
- Handle a range of bulk cargoes
 - Wet – LPG, sulphate, etc
 - Dry – Coal, Pig Iron, Clinker, etc
- Geographic features dictate vessel sizes and maximum load weights



The Problem with Jetties

→ Tend to have a fixed capacity

- Constraints on jetty and land facilities
- As volumes grow, possibility of increased queuing

→ Random nature of shipping activity

- Peaks and troughs in demands on jetty

→ Waiting ships cost money

- Penalties on late deliveries and charges for parking a ship in the port - demurrage
- Delays at one port trigger delays at other ports

→ Congestion and utilisation



Strategies for Managing Congestion

→ Increase capacity

- Either additional berths or upgrading loading/unloading – both expensive
- Reduce time between ships

→ Facility management

- Better manage time at berth
 - Shiftwork, performance and quality of onshore machinery
- Adopt pricing regime that penalises delays at berth to encourage greater efficiency

→ Queue Management

- Alter arrival patterns of vessels
- Deviate from the ‘first come - first served’ approach

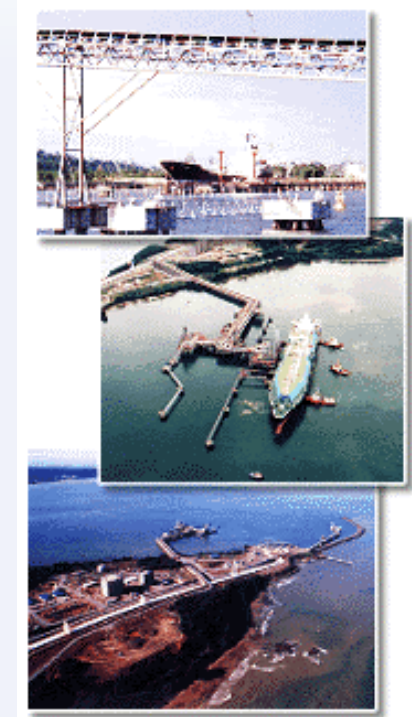

Issues in Real Life Applications

→ Availability of data

- Operational data usually incomplete
- Commercially sensitive
- Must accept proxies for key data inputs
 - Eg. Time of berthing, not arrival at port
- Small facilities have low shipping volumes



→ Time constraints

- Quick decisions needed by port management

→ System is so darned complicated

- Choosing the important things for the model

How do We Solve the Problem?

→ Three step process:

- 1. Identify variability
- 2. Create simple models
- 3. Use simulation program



→ Analyse using a mathematical model

- Simple, stable models
- Queuing theory applies

→ Better still, use a simulation model

- Can handle complex business rules
- Accurate measures
- User-friendly graphics

Identifying Variability

→ What is variable?

- Ship arrivals
- Time spent at berth

→ Sources of variability

- Cargo types and sizes
- Import (unload) or Export (load) with different rates
- Cleaning between cargos

Arrival Processes

→ Analyse inter-arrival times for each shipper

- Default model is Poisson, with exponential inter-arrivals
- Gamma inter-arrivals a more general class
- Verification by probability plots

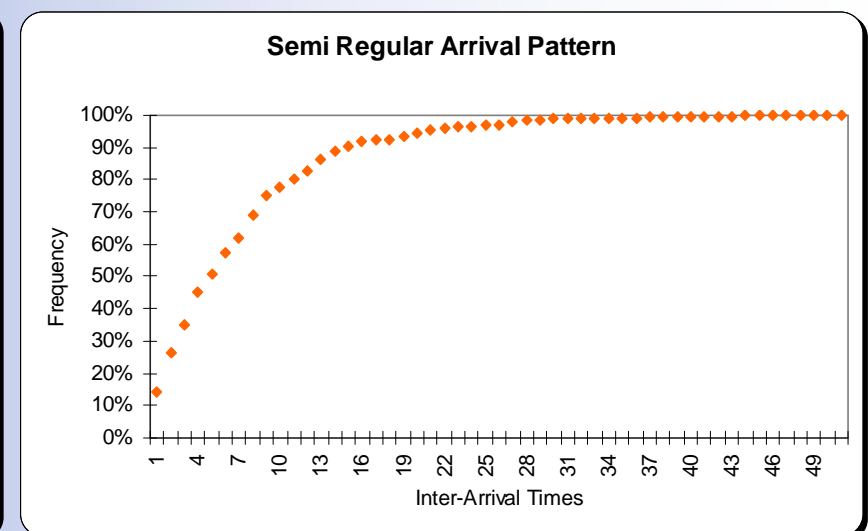
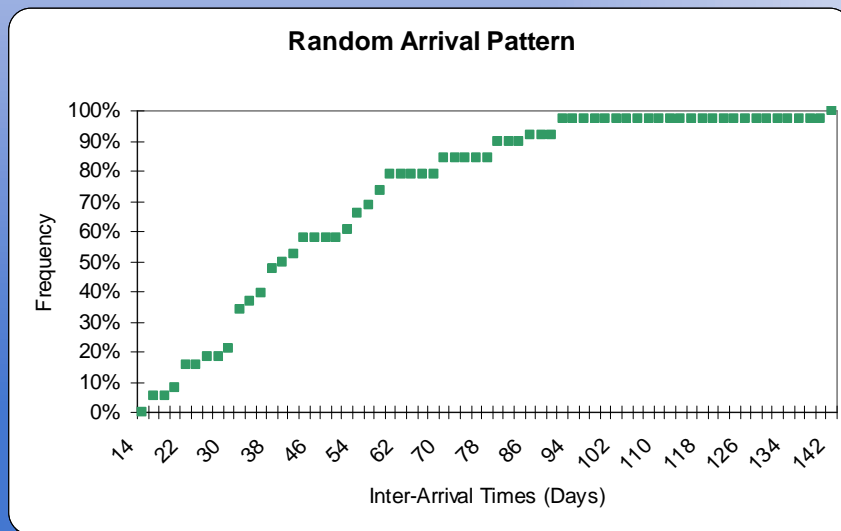

Create a Simple Model

→ Determine aspects of operations including

- Assumptions (largely the constraints)
- Design future scenarios

→ Compare scenario outcomes

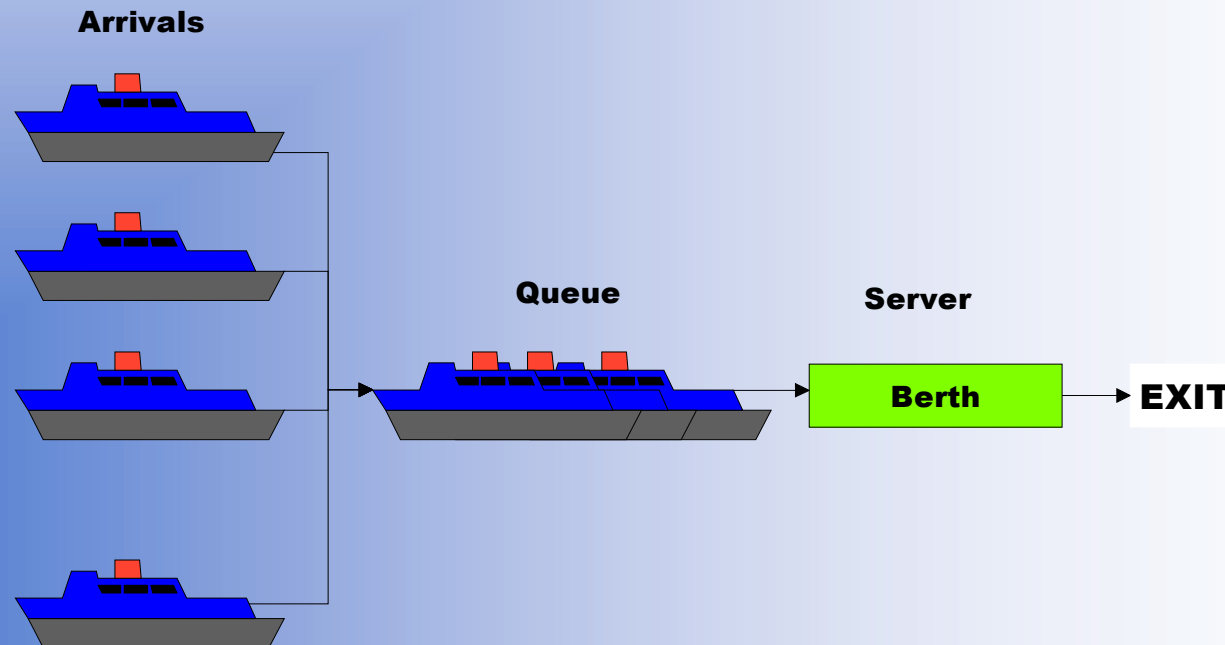

Use Simulation Program (Extend)

→ Graphical interface

→ Easy to program and operate

→ Notebook style front end (optional)

→ Blocks represent queues, routers, servers etc

→ Standard blocks provided but can build custom blocks

→ Event (ship) flows through blocks

→ Compatible with Excel

→ Player version available

Example of a Model in Extend

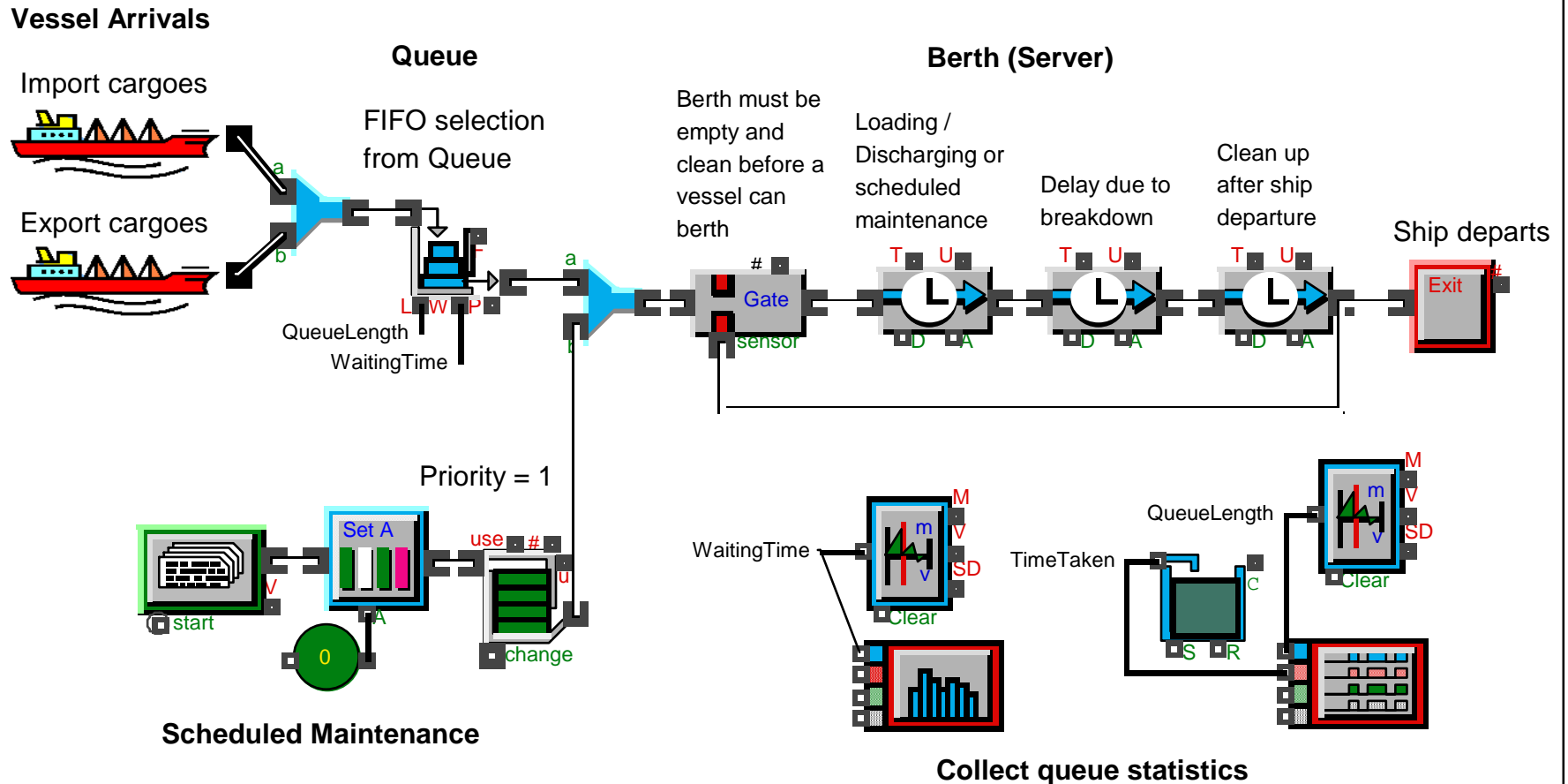

Findings

→ No patterns in most arrivals

→ Assume a Poisson arrival process for most

→ Gamma for semi-regular arrivals

- Gamma shape parameter never greater than 4

→ Service time distributions

→ Close to discrete distribution except for breakdown effects

→ Model behaved as expected

→ Congestion occurring under right conditions

→ Could determine just when it would occur

Outcome for Client

→ Forecasted when congestion will become unacceptable

→ Difference of one year critical to investment

→ Guided formation of new operating rules or conditions for the port

